



LEICA M-A

Instructions

FOREWORD

Dear Customer,

Leica would like to thank you for purchasing the LEICA M-A and congratulate you on your choice. With this unique view and rangefinder camera, you have made an excellent selection.

We wish you a great deal of pleasure and success using your new Leica.

In order to make best use of all the opportunities offered by this high performance camera, we recommend that you first of all read these instructions.

CONTENTS

Viewfinder displays	33
Attaching the carrying strap	34
Shutter release button	35
Shutter speed dial	35
Quick wind lever	35
Changing the film	36
Film sensitivity indicator	40
Fitting and removing a lens	41
Bright line view and range finder	42
Image field selector	42
Distance metering	44
Exposure control	45
Flash mode	46
Compatible flash units	46
Attaching and connecting the flash unit	46
System accessories	48
Spare parts	51
Care tips	52
Index	53
Technical data	54
Leica Product Support	56
Leica Customer Care	56

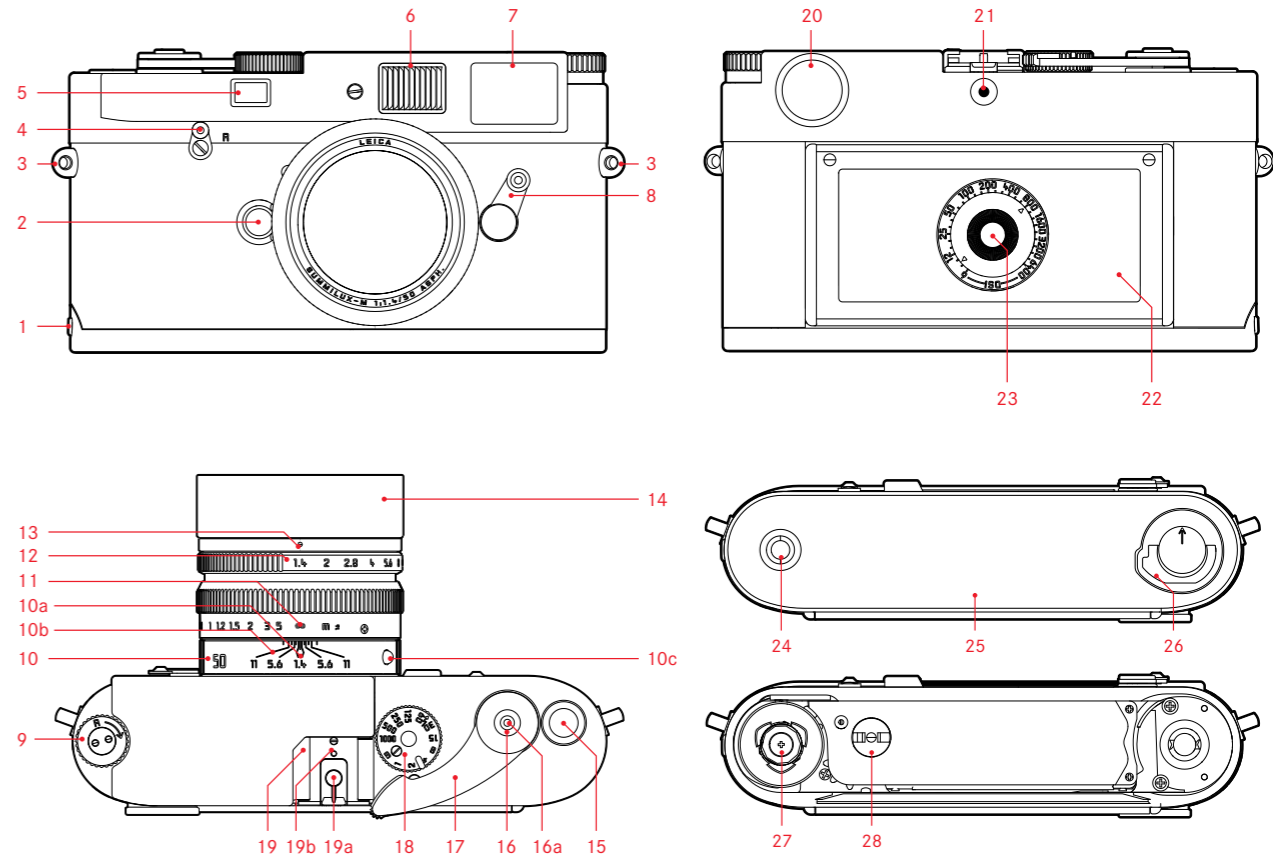

DESIGNATION OF PARTS

Front view

1. Bottom cover locking pin
2. Lens release button
3. Eyes for carrying strap
4. Rewind release lever
5. Distance meter viewing window
6. Illumination window for the bright-line frames
7. Viewfinder viewing window with silvering
8. Image field selector

Top view

9. Pull-out rewind button
10. Fixed ring with
 - a. Index for focusing
 - b. Depth of field scale
 - c. Index button for changing lenses
11. Distance setting ring
12. Aperture setting ring
13. Index point for aperture setting
14. Lens hood
15. Automatic exposure counter
16. Shutter release
 - a. Thread for cable release

17. Rapid action lever for cocking the shutter and advancing the film
18. Shutter speed dial with locking settings for:
 - Manually adjustable shutter speeds from 1 s to $\frac{1}{4000}$ s
 - Sync time $\frac{1}{50}$ s for flash mode
 - **B** for long exposures
19. Accessory/flash shoe with
 - a. Center contact
 - b. Hole for retaining pin

Rear view

20. Viewfinder window
21. Threaded flash sync socket
22. Rear panel
23. Film sensitivity indicator

Bottom view

23. Tripod thread A $\frac{1}{4}$, DIN 4503 ($\frac{1}{4}$ ")
24. Bottom cover
25. Locking toggle for bottom cover

View with bottom cover removed and rear panel open

26. Take-up spool
27. Coupling for motorized or external mechanical film winding

VIEWFINDER DISPLAYS

- a. Bright line frame for 50 mm and 75 mm (example)
- b. Metering field for distance setting

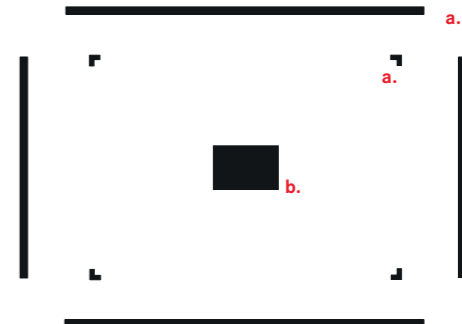

ATTACHING THE CARRYING STRAP

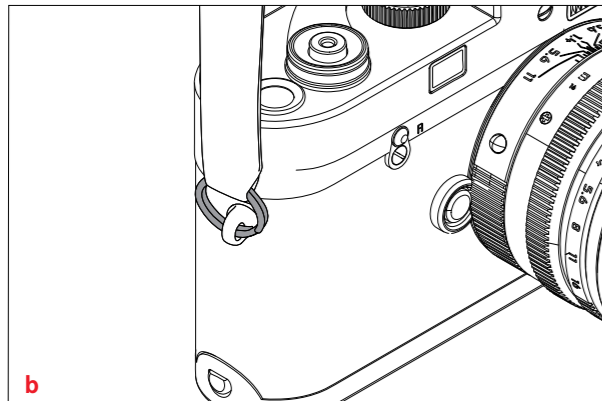
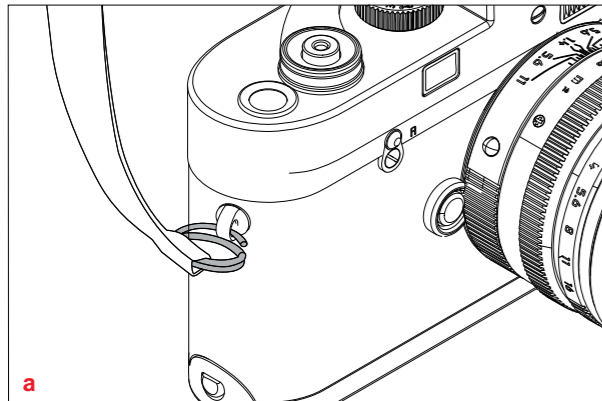

Safety notes on using carrying straps

- Carrying straps are usually made of strong material. There is therefore a risk of strangulation.
- Use them only for their intended purpose as a carrying strap on a camera/on binoculars. Any other use carries the risk of injury and may possibly result in damage to the carrying strap and is therefore not permitted.
- Due to the risk of strangulation, carrying straps should not be used for cameras/binoculars during sporting activities where there is a high risk of getting caught by the carrying strap (e.g. climbing in the mountains and comparable outdoor sports).
- Keep carrying straps away from children. They are not toys and are potentially dangerous for children. Due to the risk of strangulation, it is not suitable for children to use them as carrying straps for cameras/binoculars.

SHUTTER RELEASE BUTTON

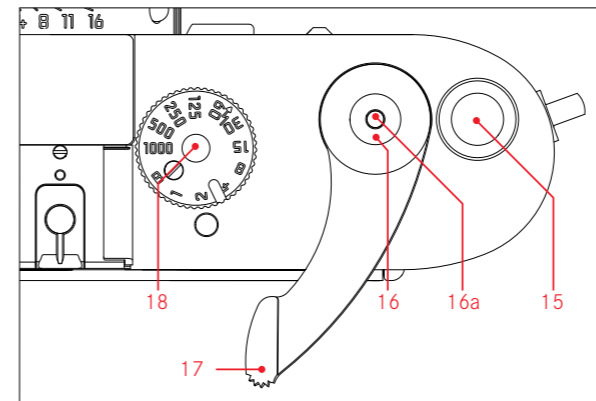

The shutter release button has a pressure point. Pressing past the pressure point releases the shutter. The shutter release button should be pressed gently – not jerkily – until the shutter is released with a soft click. The shutter release button has a standard thread for a cable release.

SHUTTER SPEED DIAL

The shutter speed dial on the Leica M-A can be used to select shutter speeds from $\frac{1}{1000}$ s to 1s, or for the sync time $\frac{1}{50}$ s for flash mode. In the **B** position, the shutter remains open for long exposures as long as the shutter release is pressed. All positions can be felt click into place, none of them are locked.

Notes:

- Intermediate values may not be used.
- Between the **1000** and **B** positions there is a stop so that other settings are only possible by turning the dial anticlockwise from the **1000** position, or clockwise from the **B** position.

QUICK WIND LEVER

The quick wind lever is used to wind the film, cock the shutter and automatically advance the exposure counter. The film can be wound either by pressing the lever as far as it will go or by pressing the quick wind lever several times. It can be folded out and left in its “ready position” for quick access.

CHANGING THE FILM

First of all, always check that a film is not already loaded by turning the pull-out rewind button in the direction of the arrow. If you feel resistance, continue as described in the "Rewinding and removing the film" section.

Take the camera in your left hand, so that the bottom cover is facing upwards.

OPENING THE CAMERA

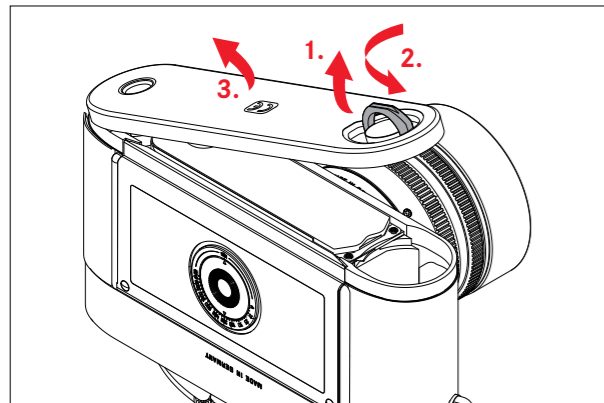

1. Fold up the toggle on the bottom cover.
2. Turn it to the left.
3. Lift off the bottom cover, and
4. Open the rear panel backwards.

LOADING A FILM

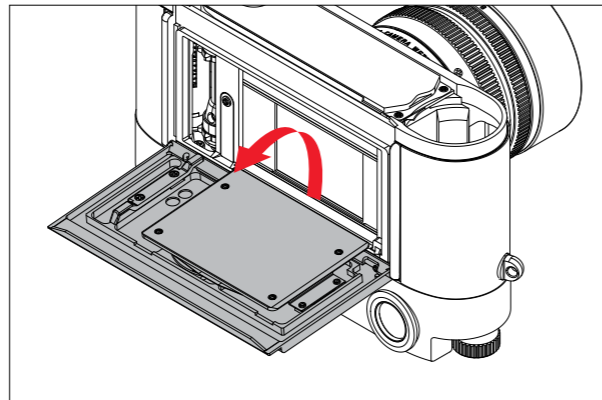

5. Take the film cartridge in the right hand and insert it around halfway into the appropriate cavity in the camera.
6. Take hold of the film leader and, as shown in the schematic diagram inside the housing, insert it into the take up spool.
7. Then carefully press the film cartridge and film leader into the camera with the fingertips.

Notes:

- As with any ready to use film, the leader must be trimmed.
- If the leader is pulled out so far that it extends a little way out of one of the slits on the opposite side of the take-up spool, this does not interfere with the camera's function. It is only in conditions of frost that the film has to be loaded exactly in accordance with the schematic diagram, i.e. the leader may only be held by one slit on the take-up spool, so that the protruding end of the films cannot snap off.

Important:

The winding of the film should not be checked with the camera open, as the bottom cover is designed in such a way that replacing it on the camera brings the film into the correct position.

CLOSING THE CAMERA

8. Close the rear panel.
9. Lower the bottom cover onto the locking pin on the side of the camera.
10. Close it, ensuring that the rear panel is completely pressed in so that the bottom cover holds it in place.
11. Lock with the toggle.

WINDING TO THE 1ST PICTURE

12. Wind the film forward one frame using the quick wind lever and release the shutter.
13. Then tension the film by carefully turning the pull-out rewind button in the direction of the arrow. The film is properly wound if the rewind button turns in the opposite direction to the arrow when the quick wind lever is operated again.
14. Finally, release the shutter again and cock the shutter a third time. The frame counter now shows **1** and the camera is ready to take a picture.

REWINDING AND REMOVING THE FILM

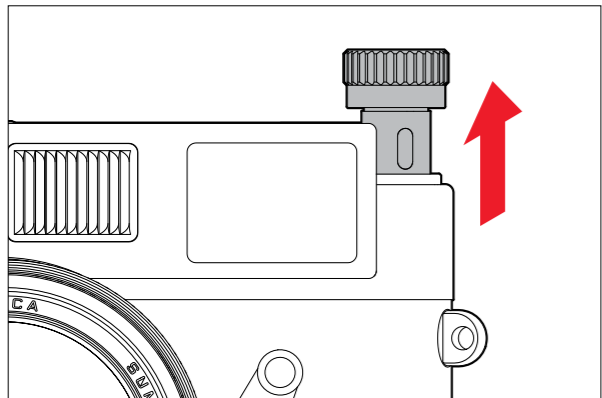
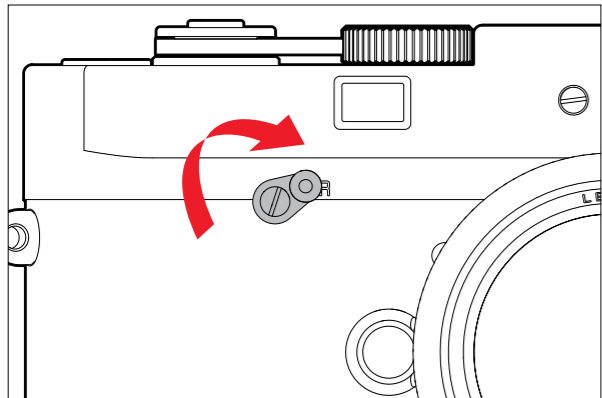

If the film has been exposed up to the last frame, the quick wind lever can no longer be operated. Before removing the film, it must be rewound into the film cartridge.

To do this:

1. Move the rewind release lever to **R**.
2. Pull out the rewind button (max. 11mm) and
3. Turn it clockwise (arrow) until the film has been wound off the take-up spool, after passing a slight resistance.
4. Open the bottom cover.
5. Open the rear panel.
6. Remove the film cartridge.

If a film is not correctly attached to the cartridge spool, e.g. when using film sold by length, it can happen that the end of the film will be torn off and will have to be removed from the take-up spool.

To do this:

1. Remove the camera's bottom cover in a completely dark room.
2. Hold the camera so that the open bottom cover is facing downwards.
3. Operate the quick wind lever slowly several times, until the film comes out of the camera by itself so that you can take hold of it and remove it. If necessary, lightly tap the camera on your hand to assist you.

FILM SENSIVITY INDICATOR

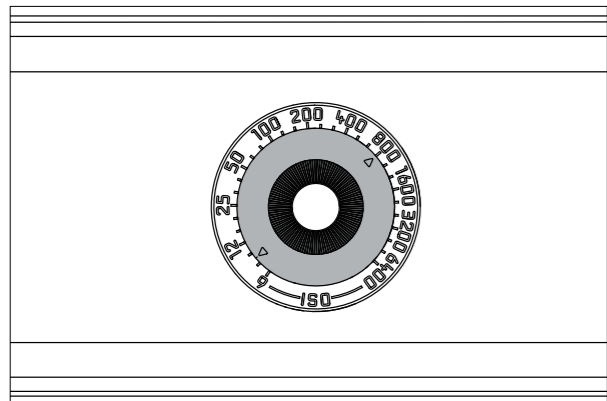

The indicator is intended as an aid to memory. It can be used to set the film sensitivity to a value in the range ISO 6 to 6400. (ISO is the international designation for film speeds)

To do this, press the non-locking

1. disc, and
2. turn it so that one of the two triangles - black for B/W films or red for color films - is pointing to the desired value.

FITTING AND REMOVING THE LENS

FITTING

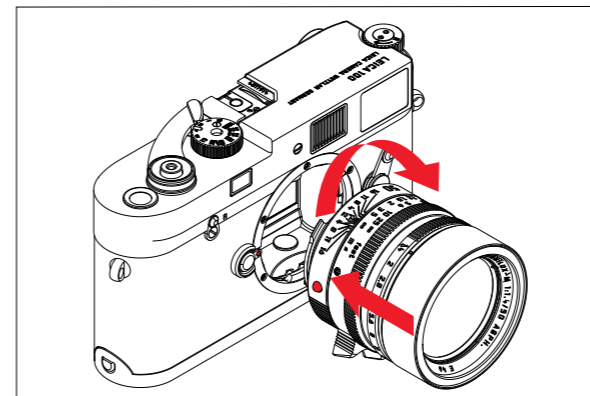

1. Hold the lens by the fixed ring.
2. Align the red index button on the lens with the release button on the camera body.
3. Then push the lens straight on in this position.
4. Turn the lens slightly to the right, and you will hear and feel it click into place.

REMOVING

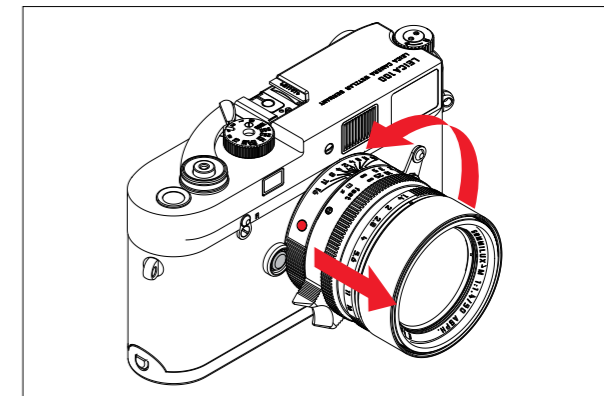

1. Hold the lens by the fixed ring.
2. Press down the release button on the camera body.
3. Turn the lens to the left until its red index button is aligned with the release button.
4. Then pull the lens straight off.

Important:

With a film loaded, you should change the lens in the shadow of your own body, as direct sunlight can result in light getting in through the shutter.

BRIGHT LINE VIEW AND RANGE FINDER

The LEICA M-A's bright-line view and range finder is not only a very high-quality, large, brilliant and bright viewfinder, it is also a highly accurate range finder coupled to the lens.

The size of the bright-lines corresponds to an image size of 23 x 35mm (slide format) at the shortest setting distance for each focal length. At longer distances, the camera records more of the subject than can be seen in the bright-lines.

The bright line frame is linked to the distance setting to ensure that parallax - the offset between the lens and the viewfinder axis - is automatically compensated.

The Leica M-A is equipped with a 0.72x magnifying viewfinder. If lenses with focal lengths of 28 mm (Elmarit from serial number 2411001 onwards), 35, 50, 75, 90 and 135mm are used, the associated bright line frame is automatically displayed in the combinations 28+90mm, 35+135mm, 50+75mm.

In the middle of the viewfinder image is the square distance metering field, which is brighter than the surrounding image field. All lenses with focal lengths from 16 to 135mm connect with the range finder when used on the LEICA M-A.

IMAGE FIELD SELECTOR

The image field selector extends the possibilities of the Leica M-A viewfinder. This built-in universal viewfinder allows you to display the image frames that do not belong to the lens currently being used at any time. You can then see immediately if, for compositional reasons, it would be better to photograph the relevant subject using a different focal length.

If the lever is rotated outwards, i.e. away from the lens, the image field limits for 35 and 135mm focal length are shown.

If the lever is moved to its vertical central position, the image field limits for the focal lengths 50 and 75mm are shown.

If the lever is moved inwards, i.e. towards the lens, the image field limits for 28 and 90mm focal length are shown.

A	Bright line frame
B	Actual image field
Set to 0.7m:	The film captures approximately one frame width less.
Set to 2m:	The film captures exactly the image field shown by the inner edges of the bright line frame.
Set to infinity:	The film captures around 1 and 4 (vertical and horizontal respectively) frame widths more.

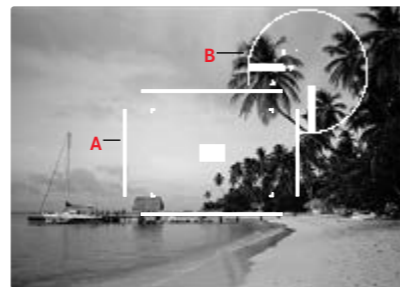

50mm + 75mm



28mm + 90mm



35mm + 135mm

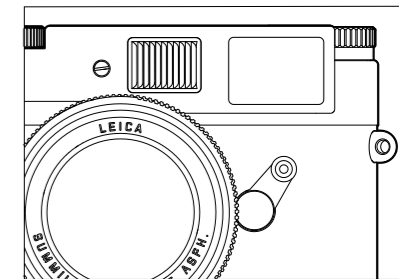
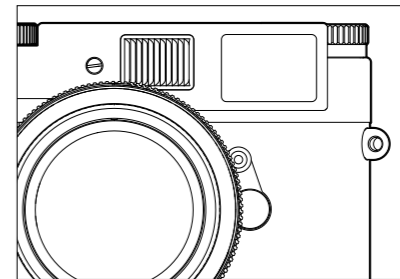
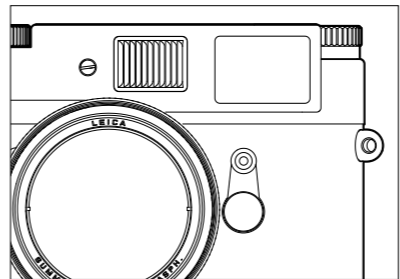

DISTANCE METERING

Due to its large effective metering basis, the range finder on the Leica M-A is very precise. The benefits of this are particularly noticeable when using wide-angle lenses with their relatively high depth of field.

The range finder metering field is visible as a bright, sharply defined rectangle in the center of the viewfinder. If you keep the large viewfinder window closed, only the activated bright-line frame and this metering field remain visible.

The focus can be set using either the superimposed image or split image method:

SUPERIMPOSED IMAGE METHOD (DOUBLE IMAGE)

In a portrait, for example, aim the metering field at the eye and turn the distance setting dial on the lens until the contours in the metering field are brought into line. Then choose the subject detail.

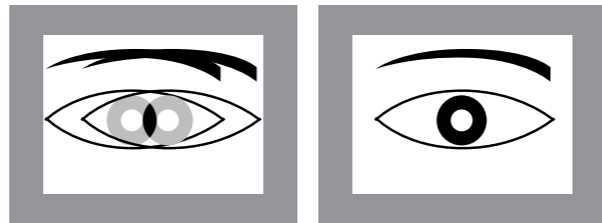

Out of focus

In focus

SPLIT IMAGE METHOD

When taking photographs of architecture, for example, aim the range finder metering field at the vertical edge or another clearly defined vertical line and turn the distance setting ring on the lens until the contours of the edge or line can be seen at the limits of the metering field with no misalignment. Then choose the subject detail.

In practice, there is often no clear distinction between the two methods. The two criteria can be used to great effect in combination.



Out of focus

In focus

EXPOSURE CONTROL

On the Leica M-A the exposure is set manually by selecting the shutter speed and lens aperture combination specified by an external exposure meter or based on your own assessment. For further details of using and adjusting exposure meters, refer to the manual for the device you are using.

FLASH MODE

The Leica M-A does not have its own flash metering and control function. As a result, flash exposures must either be controlled by an attached flash unit itself (computer control) or – using guide number calculations – the aperture must be reset for each picture according to the distance between the subject and the camera. The fastest possible shutter speed for pictures using flash units, the sync speed of $\frac{1}{50}$ s, is indicated by  on the shutter speed dial. For special effects, all slower shutter speeds including the **B** setting can also be used.

Important:

Flash units connected using the accessory shoe can still be fired mechanically when the shutter is moving by pressing the shutter release.

COMPATIBLE FLASH UNITS

With its compact dimensions and design tailored to this camera, the Leica SF26 is particularly well suited. Thanks to its computer-controlled automatic flash exposure, it is very easy to operate and furthermore offers a range of interesting additional functions. Other commercially available flash attachments with standard flash foot and positive center contact, and fired by the center contact can also be used. We recommend the use of modern thyristor-controlled electronic flash units.

Important:

When attaching a flash unit to the Leica M-A's flash shoe, you should ensure that the foot of the flash unit is fully inserted and – if present – prevented from accidentally falling out using the tightening nut. This is important because changes in position in the flash shoe can break the required contact, which means that the attached flash unit would not be fired.

Notes:

- Before attaching the flash, the camera and the flash unit must be turned off.
- For more information about use of the flash and the various modes offered by the flash units, refer to the relevant instructions.

SYSTEM ACCESSORIES

Leica M lenses

The Leica M system provides a basis for optimum adaptation to fast and unobtrusive photography. The range of lenses incorporates focal lengths from 16 to 135mm and light intensities up to 1:0.95.

Filters

UVa filters and a universal polarization filter M are available for current Leica M lenses fitted with standard filter thread sizes.

Leica Universal Wide-Angle Viewfinder M

The Leica universal wide-angle viewfinder M is a thoroughly practical accessory. It can be used without restriction on all analog and digital Leica M models and – just like the viewfinder on the camera – uses a reflected bright line frame to indicate the trimming for wide-angle focal lengths 16, 18, 21, 24 and 28mm. The viewfinder is equipped with parallax compensation and a vial (spirit level) for exact leveling of the camera.
(Order no. 12 011)

Leica Angle Finder M

Mirror viewfinders are available for 18, 21, and 24mm lenses. They feature an exceptionally compact design and a bright viewfinder image. Bright line frames like those in the camera viewfinder are used to select the trimming.
(Order no.
18mm: 12 022 black / 12 023 silver /
21mm: 12 024 black / 12 025 silver /
24mm: 12 026 black / 12 027 silver)

Leica Viewfinder magnifier M 1.25x and M 1.4x

The Leica M 1.25x and M 1.4x viewfinder magnifiers significantly simplify picture composition when using focal lengths above 35mm. They can be used on all Leica M models and magnify the central area of the viewfinder image. The 1.25x viewfinder magnifier gives the 0.72x viewfinder on the Leica M-A a magnification of 0.85x, while the 1.4x gives 0.95x magnification. A security chain with snap fasteners prevents loss and can be used to hang the viewfinder on the carrying strap's fastening ring. The viewfinder magnifiers are supplied in a leather bag. A loop on the case allows the viewfinder magnifier to be stored on the camera's carrying strap, where it is protected and ready for use.
(Order no. 12 004 M 1.25x / 12 006 M 1.4x)

Flash units

With a maximum guide number of 58 (in 105mm setting), a zoom reflector, an optional second reflector and many other functions, the Leica SF 58 system flash unit (order no. 14 488) is both powerful and versatile.

With its compact dimensions and design that matches the camera, the Leica SF 26 system flash unit (order no. 14 622) is the perfect solution. Like the Leica SF 58, it is extremely easy to operate.

Leica Lens Holder M

A practical little accessory, which allows you to keep a second lens to hand, held securely under the camera, with quick and easy access at any time. The second lens can act as a comfortable handle. The M lens holder is attached to the camera's tripod thread.

(Order no. 14404)

Leica Corrective Lenses M

For optimum adaptation of the eye to the camera's viewfinder, we offer corrective lenses with the following positive or negative diopter values (spherical): 0.5/1/1.5/2/3

LEICA MOTOR M

The Leica Motor M for automatic shutter cocking and film winding for single or series exposures of either 1.5 or 3 frames per second can be connected to the Leica M-A. It is attached to the bottom of the camera housing instead of the bottom cover. The Motor M is suitable for all shutter speeds, i.e. from 1s to $\frac{1}{1000}$ s including the **B** setting. When the Motor M is turned off or its batteries are flat, the film can be wound and the shutter cocked manually.

(Order no. 14408)

LEICAVIT M

The Leicavit M is a smooth running and low-noise manual lever wind for winding the film and cocking the shutter, and is attached to the bottom of the camera instead of the bottom cover. Without having to take the camera away from your eye, you can wind the film by moving a swing-out winding lever to the left; partial steps are also possible. The shutter is released using the camera's shutter release button. The camera's quick wind lever can also be used.

The Leicavit M is available in silver, black chrome finish or black painted.

(Order no. 14008 / 14450 / 14009)

Cases

Two neoprene carrying cases are available for the Leica M-A with different front sections for different lens lengths, as well as classic leather carrying cases in various styles of leather and a range of colors. (Order no. 14 867 short / 14 868 long / 14 875 / 14 876 / 14 857 - 14 865 leather / 14 856 leather, for camera with Leicavit attached).

For your full set of camera equipment, the classic Billingham combination case made of waterproof fabric is also available. This either holds two cameras and two lenses or one camera and three lenses. It has enough space for even large lenses and a fitted M hand grip. A zipped compartment also provides space for a Leica SF 26 flash and for other accessories.

(Order no. 14 854 black / 14 855 khaki).

Spare parts

	Order no.
Carrying strap	14 312
Housing bayonet cover.....	14 397

Order no.

CARE TIPS

If your Leica will not be used for a long period, ensure that it is stored in a dry, well ventilated location.

Photo cases that became wet during use should be emptied to prevent damage to your equipment caused by moisture and any leather-tanning residue released. To prevent fungal growth during use in hot, humid tropical climates, the camera equipment should be exposed to the sun and air as much as possible. Storage in airtight containers or cases is only recommended if a desiccant, such as silica gel, is also used.

As any dirt may also be a breeding ground for micro-organisms, the equipment should be carefully kept clean.

All mechanically operated bearings and sliding surfaces on your Leica are lubricated. Please remember this if you will not be using the camera for a long period of time. To prevent the lubrication points from becoming gummy, the camera should be wound on several times and released with every shutter speed with no film loaded every three months. It is also recommended that you repeatedly move and use all other controls, such as the image field selector.

A lens works like a magnifying glass if bright sunlight shines on the front of the camera. The camera should therefore never be set aside without protection against strong sunlight. Fitting the lens cover and keeping the camera in the shade (or directly in the case) help to prevent damage to the interior of the camera. To remove stains and fingerprints, the camera should be wiped with a clean lint-free cloth. Tougher dirt in hard to reach corners of the camera body can be removed with a small brush.

Do not use liquid cleaning agents to clean the housing. Dust and lint inside the camera (e.g. on the film guides) are best removed carefully with a soft hair brush that has been repeatedly degreased in alcohol and then dried. Be careful not to damage the shutter curtain with the shaft of the brush.

Note the serial number of your Leica M-A (engraved on the accessory shoe), as it is extremely important in case of loss.

INDEX

Accessories	48
Attaching and removing lenses.....	41
Bright-line / View and range finder.....	42
Care tips.....	52
Carrying strap	34
Cases	51
Corrective lenses	50
Distance setting.....	44
Split image method	45
Superimposed image method	44
Exposure control.....	45
B setting.....	35
Film	
Loading.....	36
Rewinding and removing.....	38
Film indicator.....	40
Filters	48

Flash mode.....	46
Synchronization.....	46
Image field selector.....	42
Lenses, Leica M.....	48
Quick wind lever	35
Repairs / Leica Customer Care.....	56
Shutter release, see Technical data.....	35/54
Shutter speed setting dial	35
Shutter, see Shutter release and Technical Data.....	35/54
Technical data	54
Viewfinder.....	42
Bright line frame.....	42/43
Detachable viewfinder	48

TECHNICAL DATA

Camera type LEICA M-A (Typ 127) Compact 35mm range and viewfinder system camera with mechanically controlled shutter

Lens connection Leica M bayonet

Lens system Leica M lenses from 16–135mm

Exposure control Manual shutter speed and aperture setting based on readings from external exposure meter or operator assessment

Flash exposure control

Flash unit connection Using accessory shoe with center contact

Synchronization With 1st shutter curtain

Flash sync speed $\frac{1}{50}$ s; slower shutter speeds can be used

Flash exposure control Computer control of flash unit or guide number calculation and manual setting of required aperture

Viewfinder

Viewfinder principle Large, bright line frame viewfinder with automatic parallax compensation

Eyepiece Calibrated to -0.5 dpt. Corrective lenses from -3 to $+3$ diopter available

Image field limiter By activating two bright lines each: For 28 and 90mm or for 35 and 135mm, or for 50 and 75mm; automatic activation when lens is fitted

Image field selector Allows the bright-line pairs to be manually activated at any time (e.g. to compare detail)

Parallax compensation Horizontal and vertical offset between viewfinder and lens axis is automatically compensated according to the relevant distance setting

Correlation between viewfinder and film images At the shortest possible distance setting for each focal length, the bright line frame size corresponds to an image size of approx. 23 x 35mm. When set to infinity, depending on the focal length between 9% (28mm) and 23% (135mm) more is captured by the film than is shown in the corresponding bright line frame

Magnification (For all lenses) 0.72x

Large basis range finder Split or superimposed image range finder shown as a bright field in the center of the viewfinder image

Effective measurement basis 49.9mm (mechanical measurement basis 69.25mm x viewfinder magnification 0.72x)

Shutter and shutter release

Shutter Rubber blanket slotted shutter with horizontal movement; extremely low-noise; mechanically controlled

Shutter speeds From 1s to $\frac{1}{1000}$ s in whole increments, **B** for long exposures of any duration, $\frac{1}{50}$ s for flash synchronization

Shutter release Standard thread for cable release integrated

Film winding

Loading Manual film loading after opening the bottom cover and the rear panel

Winding forwards Manually with quick wind lever or Leicavit M, motorized using Leica Motor-M, Leica Winder-M, Leica Winder M4-P, or Leica Winder M4-2 (from serial no. 10 350)

Rewind Manually with pull-out rewind button, after moving the R lever on the front of the camera

Frame counter On top of camera; automatic reset when bottom cover is removed

Camera body

Material Enclosed all-metal body with hinged rear panel; chromed brass top and bottom cover

Tripod thread A $\frac{1}{4}$ DIN 4503 ($\frac{1}{4}$ "

Rear panel/equipment Indicator for film sensitivity

Dimensions (Length x Depth x Height, in mm)
Approx. 138 x 38 x 77

Weight Approx. 578g

Items supplied Housing bayonet cover, carrying strap

LEICA PRODUCT SUPPORT

The Product Support department at Leica AG can provide you with an answer to any technical questions relating to Leica products, including software supplied, either in writing, on the telephone or by e-mail.

They are also the contact point for purchasing advice and to order instruction manuals. Alternatively, you can send us your questions using the contact form on the Leica Camera AG homepage.

Leica Camera AG

Product Support / Software Support

Am Leitz-Park 5

D-35578 Wetzlar

Telephone: +49(0)6441-2080-111 /-108

Fax: +49(0)6441-2080-490

info@leica-camera.com / software-support@leica-camera.com

LEICA CUSTOMER CARE

For servicing your Leica equipment or in the event of damage, the Leica Camera AG Customer Care department or the repair service provided by authorized Leica agents in your country are available (see the Warranty Card for a list of addresses).

Leica Camera AG

Customer Care

Am Leitz-Park 5

D-35578 Wetzlar

Telephone: 06441 2080-189

Fax: 06441 2080-339

customer.care@leica-camera.com